

ORDINANCE NO. 2014-A

**AN ORDINANCE REGULATING THE USE
OF THE PARKS AND PROPERTY OWNED OR CONTROLLED
BY THE WHEELING PARK DISTRICT,
COOK AND LAKE COUNTIES, ILLINOIS
("CONDUCT ORDINANCE")**

*** * * * ***

Adopted January 7, 2014

**(Published by Authority of the Board of Park Commissioners
of the Wheeling Park District
on January 7, 2014.)**

TABLE OF CONTENTS

<u>SECTION</u>	<u>DESCRIPTION</u>	<u>PAGE</u>
CHAPTER I	DEFINITIONS, CONSTRUCTION, AND SCOPE	1
1.01	Short Title	1
1.02	Definitions	1
1.03	Construction and Scope	3
CHAPTER II	SPECIFIC RESTRICTIONS ON CONDUCT AND BEHAVIOR	4
2.01	Aircraft/Model Aircraft	4
2.02	Alcoholic Liquor	4
2.03	Animals and Pets	5
2.04	Assault or Bodily Injury	6
2.05	Begging and Panhandling	6
2.06	Boating	6
2.07	Camping	7
2.08	Charitable, Religious, Political, or Non-Profit Activities	7
2.09	Commercial Sale, Exhibition, or Distribution of Goods or Services	7
2.10	Controlled Substances and Cannabis	8
2.11	Cooperation with Authorities	8
2.12	Disorderly Conduct	8
2.13	Display of Permit or Pass	9
2.14	Dumping, Pollution, Sanitation, and Litter	9
2.15	Erection of Structures/Wires	10
2.16	Fairs and Special Events: Sale and Distribution of Merchandise; Soliciting Contributions	10
2.17	Fires	10
2.18	Fishing	10
2.19	Gambling and Games of Chance	11
2.20	Hunting or Trapping	11
2.21	Interference with Other Users	11
2.22	Loitering in District Buildings	11
2.23	Misappropriation of Property	11
2.24	Mob Action	12
2.25	Parades, Public Assemblies, or Meetings	12
2.26	Posting Printed or Written Material in Designated Area	13
2.27	Posting Printed or Written Material on Public Places or Objects	13
2.28	Protection of Animals	13
2.29	Protection of Property	14
2.30	Public Indecency	14
2.31	Reporting Accidents	15
2.32	Restricted Areas	15

<u>SECTION</u>	<u>DESCRIPTION</u>	<u>PAGE</u>
2.33	Restrictions Applicable to Specific Recreational Activities	15
2.34	Rest Rooms, Locker Rooms and Washrooms	16
2.35	Roller Skates, Skateboards, and Other Similar Objects	17
2.36	Selling or Distributing Printed or Written Material	17
2.37	Sledding, Ice Skating, and Snowmobiling	17
2.38	Sleeping on District Property	17
2.39	Smoking	18
2.40	Swimming	18
2.41	Weapons, Fireworks, Explosive, Rockets	18
CHAPTER III	MOTORIZED VEHICLES, PARKING, AND TRAFFIC CONTROL	20
3.01	All-Terrain Vehicles	20
3.02	Bicycles	20
3.03	Change of Oil/Cleaning	22
3.04	Commercial Vehicles	22
3.05	Driving Areas	22
3.06	Duty of Operator in Accidents	22
3.07	Emergency Vehicles	22
3.08	Enforcement of Traffic Regulations	23
3.09	Fleeing or Attempting to Elude the District Police Force	23
3.10	Gas and Smoke	23
3.11	Hitchhiking	23
3.12	Incorporation of State Statutes	23
3.13	Intoxicated Operators	23
3.14	Minibikes, Motorized Scooter and Trailbikes	24
3.15	Negligent Driving	24
3.16	Parking	24
3.17	Riding Outside Vehicles	27
3.18	Right of Way	27
3.19	Siren Devices	27
3.20	Speeding	28
3.21	Traffic Signs and Signals	28
3.22	Unattended Motor Vehicles	28
3.23	Unauthorized Use of Parking Places Reserved for Handicapped Persons	28
3.24	Use of Electronic Personal Assistive Mobility Devices (EPAMD) in District Facilities and at District Parks	29
CHAPTER IV	PARK HOURS, CLOSING, AND GENERAL OPERATION POLICIES	30
4.01	Hours	30
4.02	Special Closings	30
4.03	Use of Closed Property Prohibited	30

<u>SECTION</u>	<u>DESCRIPTION</u>	<u>PAGE</u>
4.04	Schedules, Fees, Rules, and Regulations	31
4.05	Admission/Identification	31
4.06	Lost, Found, and Abandoned Property	31
4.07	Building Use	31
4.08	Soccer Goal Safety and Education Policy	32
CHAPTER V	PERMITS AND OTHER AUTHORITY	40
5.01	Permits	40
5.02	Insurance and Hold Harmless Agreement	43
5.03	Restoration Deposit	43
5.04	Other Authority	43
CHAPTER VI	ENFORCEMENT	44
6.01	Police/Security Force	44
6.02	Rules to be Obeyed	44
6.03	Parties to Ordinance Violation	44
CHAPTER VII	PENALTIES	44
7.01	Revocation of Privileges; Fine	44
7.02	Restitution	45
7.03	Seizure/Removal/Impoundment of Property	45
7.04	Non-Exclusivity of Penalties	45
CHAPTER VIII	REPEAL	45
CHAPTER IX	SEVERABILITY	45
CHAPTER X	PUBLICATION AND EFFECTIVE DATE	45
10.01	Publication in Book Form	45
10.02	Effective Date	46

**AN ORDINANCE REGULATING THE USE OF THE PARKS
AND PROPERTY OWNED OR CONTROLLED BY THE
WHEELING PARK DISTRICT**

CHAPTER 1 - DEFINITIONS, CONSTRUCTION, AND SCOPE

Section 1.01. Short Title. This Ordinance regulating the use of the parks and property owned or controlled by the Wheeling Park District shall be known and may be cited as the "Conduct Ordinance of the Wheeling Park District."

Section 1.02. Definitions. Unless otherwise expressly stated elsewhere in this Ordinance, for purposes of this Ordinance, the following words, terms, and phrases shall have the meanings given herein:

1. "Aircraft" means any device that is used or intended to be used for human flight in the air or is capable of flight in the air, including without limitation powerless flight.
2. "Alcoholic Liquor" is defined as provided in the Illinois Liquor Control Act of 1934 (235 ILCS 5/1-3.05) as amended hereafter.
3. "Aquatic Life" means all fish, reptiles, amphibians, crayfish, mussels, mollusks, and crustaceans.
4. "Board" means the Board of Park Commissioners of the Wheeling Park District.
5. "Camping" shall include the erecting of a tent or shelter of natural or synthetic material, preparing a sleeping bag, hammock, or other bedding material for use, setting up any temporary or permanent camping equipment including without limitation food preparation equipment, and parking of a motor vehicle, motor home or trailer, or mooring of a vessel, for the apparent purpose of overnight occupancy.
6. "Cannabis" is defined as provided in the Illinois Cannabis Control Act (720 ILCS 550/3(a) as amended hereafter.
7. "Carry" means to wear, bear, or have on or about the person.
8. "Controlled Substance" is defined as provided in the Illinois Controlled Substances Act (720 ILCS 570/102 (f), 204, 206, 208, 210 and 212 as amended hereafter.
9. "Director" is the Executive Director of the Wheeling Park District.
10. "District" is the Wheeling Park District, Cook and Lake Counties, Illinois.
11. "District Police Force" shall include the members of the Lake County Sheriff's Police, and the Village of Wheeling Police Department.

12. "District Property" is all of the property, real and personal, of every kind and description located within the jurisdiction of, or owned, administered, leased or licensed by, or otherwise in the possession or under the control of the District including without limitation every building, shelter, street, sidewalk, trail, path, beach, park, wilderness or open space, or other public place or facility and all District Waters located on or adjacent to or flowing over property located within the jurisdiction of, or owned, administered, leased or licensed by, or otherwise in the possession or under the control of the District.

13. "District Waters" shall include all water located on or adjacent to or flowing over land owned, leased, or generally administered or operated by the Wheeling Park District, including without limitation all natural or man-made lakes, rivers, creeks, streams, ponds, lagoons, bays, and drainage ways.

14. "Department Head" is the person immediately in charge of a given District department and its activities and to whom all employees of such department are directly responsible.

15. "Fish" or "Fishing" means taking or attempting to take aquatic life in or from any District Waters by any method, and all other acts such as placing, setting, drawing or using any device commonly used for the taking of aquatic life whether resulting in such taking or not.

16. "ILCS" is the Illinois Compiled Statutes.

17. "Operator" means a person who operates, drives, controls, otherwise has charge of, or is in actual physical control of a mechanical mode of transportation or any other mechanical equipment.

18. "Ordinance" means the Conduct Ordinance of the Wheeling Park District.

19. "Park Security" is the Park Security for the Wheeling Park District.

20. "Permit" is the written authorization issued by or under the authority of the District, by a District officer or employee empowered to grant said authorization, to a Person to do or engage in a particular act or acts on District Property. Said authorization is subject to the terms and conditions specified in the Permit as well as all applicable federal, state, local, and District laws, ordinances, rules, and regulations.

21. "Person" is every natural person and every organization, firm, partnership, association, corporation, or entity of any kind or any employee, agent or officer thereof. This definition shall not include the District and any authorized officer, employee (full- or part-time, regular or short-term), or agent of the District when acting within the scope of his authority.

22. "Possess" or "Possession" means exercising direct physical control or dominion, with or without ownership, over any kind of property, or archeological, cultural or natural resource.

23. "Refuse" includes without limitation trash, garbage, rubbish, waste, papers,

bottles or cans, debris, litter, oil, solvents, liquid waste, or other discarded material whether solid or liquid.

24. "Services" shall include but not be limited to labor, professional services, transportation, leasing or renting any article, object, privilege, or service, giving of instructions or lessons, admission to exhibits, use of telephone or other utilities, or any act for which payment is customarily received.

25. "Smoking" means the lighting of cigarettes, cigars or pipes, the carrying of lighted cigarettes, cigars or pipes, or the intentional and direct inhalation of smoke from these objects.

26. "Take" or "Taking" means to pursue, hunt, harass, lure, harm, shoot, trap or ensnare, gig or spear, net, capture, collect, kill, destroy, wound, or attempt to do any of the above.

27. "Vehicle" means every device in, upon, or by which a person or property is transported or drawn on land, whether motor powered or self-propelled, except baby carriages, or strollers bicycles when properly used on walks or trails, and vehicles in the service of the District.

28. "Vessel" means every type or description of craft, other than a seaplane on water, used or capable of being used as a means of transportation on water, including without limitation boats, rafts, canoes, kayaks, jet skis, inflated devices, or any buoyant device permitting or capable of free flotation.

29. "Wildlife" shall include any water fowl, mammal, animal, amphibian, reptile, or bird or the young or eggs thereof.

30. "Gang Related Activity" shall include the display or possession of gang related symbols, the use of hand signals, soliciting membership, intimidating or threatening behavior, wearing or displaying any gang colors or clothing identified with gang activities.

31. "Authorized Personnel" shall include Park District staff and District Police Force.

32. "Electronic Personal Assistive Mobility Device" (EPAMD) means a device used by a person with a mobility impairment for ambulation. This definition does **not** include gasoline-powered devices, golf cars, or riding lawn mowers.

Section 1.03. Construction and Scope.

(a) In the interpretation of this Ordinance, its provisions shall be construed as follows: (1) Where the context permits, words in the masculine gender shall include the feminine and neuter genders and words in the singular number shall include the plural number; (2) The word "shall" is always mandatory and not merely directory; (3) The word "may" is always permissive and upon the discretion of the District; (4) This Ordinance is in addition to and supplemental to all applicable state, federal, local, and District laws, ordinances, rules, and regulations including without limitation the Park District Code (70 ILCS 1205/1-1 *et seq.*); (5)

The meaning of any term, phrase, or word not otherwise defined in this Ordinance shall be construed and interpreted to mean the same as said term, phrase, or word is otherwise defined, construed or interpreted in such applicable federal, state, local, or District laws, ordinances, rules, or regulations; (6) The meaning of any term, phrase, or word not otherwise defined in this Ordinance or in such applicable federal, state, local, or District laws, ordinances, rules, or regulations shall retain its ordinary and properly understood meaning; (7) The descriptive headings of the various sections or parts of this Ordinance are for convenience only and shall not affect the meaning or construction, nor be used in the interpretation of any provision of this Ordinance; and, (8) An attempt to commit an act or engage in an activity prohibited under this Ordinance shall likewise be deemed prohibited in the same manner as the commission of such act or the engaging in such activity and subject to the same penalties.

(b) This Ordinance shall apply to and be enforceable within and upon all District Property, and shall regulate the use thereof by all Persons. However, no provision hereof shall make unlawful any act necessarily performed by any officer, employee or agent of the District, member of the District Police Force when acting within the scope of his authority or in his line of duty, or any other Person summoned by such person to assist him.

CHAPTER II - SPECIFIC RESTRICTIONS ON CONDUCT AND BEHAVIOR

Section 2.01. Aircraft/Model Aircraft.

(a) No Person shall fly, cause to be flown or permit or authorize the flying of Aircraft of any kind at any time over District Property at an elevation lower than the minimum safety requirements established by the Federal Aviation Administration or other governmental authority, at an elevation which is lower than is reasonably safe under the circumstances, or in a manner which endangers the safety of any Person on District Property.

(b) No Person shall land, cause to be landed, or permit or authorize the landing of any Aircraft on District Property, except when necessitated by unavoidable emergency.

(c) No Person shall fly or cause to be flown or permit or authorize the flying of model Aircraft on or over District Property unless a Permit therefor has first been obtained from the District in accordance with Chapter V of this Ordinance.

(d) No Person shall parachute or otherwise descend from an Aircraft into or onto District Property or cause, permit or authorize another Person to parachute or otherwise descend from an Aircraft into or onto District Property except when necessitated by unavoidable emergency.

Section 2.02. Alcoholic Liquor.

(a) No Person under the influence of Alcoholic Liquor intoxicating liquor, other drug, or a combination thereof, as defined in Section 11 – 501 of the Illinois Vehicle Code (625 ILCS 5/11-501), shall enter into, be, or remain on District Property.

(b) No Person, other than the District or its agent, shall sell or deliver any Alcoholic

Liquor on District Property, unless said Person has first obtained a Permit therefor from the District.

(c) No Person shall bring into, possess, drink, consume, take, use, or transfer any Alcoholic Liquor on District Property, except in designated areas of the Chevy Chase Country Club, without having first obtained a Permit therefor from the District.

(d) Every Person possessing, using, consuming, or transferring Alcoholic Liquor pursuant to this section, shall be subject to and shall comply with all applicable federal, state, local, and District laws, ordinances, rules, and regulations regarding the possession, use, consumption, or transfer of Alcoholic Liquor.

Section 2.03. Animals and Pets.

(a) No Person shall bring or release onto District Property any Wildlife including without limitation any animal the capture or killing of which is authorized by the fish and game laws of the State of Illinois, or any other animal, except for domestic dogs, cats or other domesticated animal subject to the restrictions contained in this section. Provided, however, that the District may bring or release, or permit another Person to bring or release such proscribed animals onto District Property in conjunction with an activity or event conducted or sponsored by the District or in conjunction with a zoo, museum, nature center, or similar facility controlled, permitted or licensed maintained by the District.

(b) No owner or agent of the owner having control of any domestic dog, cat, or any other domesticated animal shall cause or permit such animal to be on District Property unless the pet is on a leash which shall not exceed six (6) feet in length and such Person has in his immediate possession a device for removal, and a depository for the transportation of, animal excrement from such Property.

(c) No owner or agent of the owner having control over any domestic dog, cat, or any other domesticated animal shall secure that pet by a leash to any tree, fence or other fixed object on District Property.

(d) All owners or agents of the owner having control of any domestic dog, cat, or other domesticated animal, shall remove any excrement from District Property left by such animal.

(e) No Person shall bring a domestic dog, cat, or any other animal onto or permit any animal to remain on any portion of District Property where the presence of animals is prohibited.

(f) Any animal found on District Property in violation of subsections (a) or (d) may be apprehended, removed to an animal shelter, public pound, or other place provided for that purpose, and disposed of pursuant to the laws or ordinances of Cook and Lake Counties. The owner or Person responsible for such animal shall be responsible for all costs and expenses incurred or encumbered in the removal and housing of such animal and such charge shall be in addition to and not in lieu of any other penalties provided for in this Ordinance and any other applicable federal, state, local or District laws, ordinances, rules or regulations.

(g) Dogs for the visually impaired and other domesticated animals specially trained to assist Persons with disabilities are excluded from the prohibitions of this section when they are accompanying Persons with disabilities for purposes of providing such assistance.

Section 2.04. Assault or Bodily Injury.

(a) No Person shall, without lawful authority, engage in conduct on District Property that which places another Person in reasonable apprehension of receiving bodily harm or physical contact of an insulting or provoking nature.

(b) No Person shall intentionally or knowingly by any means cause bodily harm or make physical contact of an insulting or provoking nature with another Person on District Property.

Section 2.05. Begging and Panhandling.

(a) No person shall beg or panhandle in District buildings or facilities or the entrances or stairways of such buildings or facilities.

(b) No Person begging or panhandling on the Park District Property shall obstruct or impede pedestrians or Vehicles; harass park visitors with physical contact or persistent demands; misrepresent his affiliations; misrepresent what the solicited funds will be used for; or interfere, interrupt, or engage in conduct incompatible with the purpose of any program, activity, function, and/or special event conducted, sponsored licensed or otherwise permitted by the District; or coerce or intimidate another person into giving money, goods or services.

Section 2.06. Boating.

(a) No Person shall launch any Vessel in District Waters, except from such places as may be designated therefor, and then only in compliance with applicable federal, state, local, and District laws, ordinances, rules, and regulations.

(b) No Person shall use, employ, or be in or upon any District launching ramp or Vessel except on dates and during hours and established by the District.

(c) No Person shall use or employ any District Property designated such for the launching or removal of sail boats, power boats, or other Vessels, unless he has purchased and is displaying a current daily fee ticket or a current season Vessel launching permit.

(d) No Person shall allow any Vessel or watercraft equipment or accessories to remain on District Property beyond the close of the boating season designated by the District, other than in a storage area designated by the Park District.

(e) No person may launch or remove a Vessel on or from District Property unless said Vessel has successfully pass a United States Coast Guard safety inspection.

Section 2.07. Camping. No Person shall place, erect, or use any hammock, swing, tent, shelter, or any other type of temporary or permanent housing or camping equipment on District Property, nor otherwise camp in any manner on District Property unless a Permit therefor has first been obtained from the District.

Section 2.08. Charitable, Religious, Political, or Non-Profit Activities.

(a) For purposes of this section, charitable, religious, political, or non-profit activities shall include, without limitation soliciting contributions, the sale or distribution of merchandise, soliciting votes or circulating petitions for or against any candidate for election to public office with respect to any referendum or other public question.

(b) Soliciting contributions for charitable, religious, political, or non-profit organizations is permitted on District Property provided that a Permit therefor has first been obtained from the District in accordance with Chapter V of this Ordinance.

(c) The sale or distribution of merchandise by charitable, religious, political, or non-profit organizations is permitted on District Property provided that a Permit therefor has first been obtained from the District in accordance with Chapter V of this Ordinance.

(d) Soliciting votes and circulating petitions for or against candidate for election to public office or with respect to any referendum or other public question is permitted on District Property in areas open to the general public without a permit, subject to the limitations set forth in paragraphs (e) and (f) of this Section 2.08.

(e) No Person shall engage in any activity described in subsections (a) through (d) of this Section 2.08 in District buildings or facilities in rooms in which any program, activity, class, function or special event conducted, sponsored by the District is in progress.

(f) No Person engaged in the activities described in subsections (a) - (d) of this section shall obstruct or impede pedestrians or Vehicles, harass park visitors with physical contact or persistent demands, misrepresent the affiliations of those engaged in such activities, misrepresent what the solicited funds will be used for or whether the merchandise is available without cost or donation, or interfere, interrupt, or engage in conduct incompatible with the purpose of any program, activity, function, and/or special event conducted or sponsored by the District.

Section 2.09. Commercial Sale, Exhibition, or Distribution of Goods or Services.

(a) No peddler, vendor or any other Person involved in an endeavor for profit shall engage in the commercial sale, rental, exhibition, or distribution of goods or services, including without limitation the giving of instruction or lessons for a fee, upon District Property unless he has received a Permit, license or contract therefor from the District.

(b) No Person engaged in the sale or distribution of goods or services under this section shall obstruct or impede pedestrians or Vehicles, harass park visitors with physical contact or persistent demands, misrepresent the affiliations of those engaged in such activities,

misrepresent whether the goods or services are available without cost or donation, or interfere, interrupt, or engage in conduct incompatible with the purpose of any program, activity, function, and/or special event conducted, sponsored licensed or otherwise permitted by the District.

Section 2.10. Controlled Substances and Cannabis.

(a) No Person under the influence of any Controlled Substance or Cannabis shall enter into, be, or remain on District Property.

(b) No Person shall bring into, possess, take, use, sell, or transfer any Controlled Substance or Cannabis on District Property.

Section 2.11. Cooperation with Authorities.

(a) No Person shall physically hinder, threaten, resist, intimidate, disobey, or otherwise intentionally interfere with any member of the District Police Force or any District employee or agent in the performance of his duties.

(b) No Person shall falsely represent that he is, or otherwise pretend to be, a District officer or employee, a member of the District Police Force, or an agent or other representative of the District.

(c) No Person shall knowingly give a false report or false information (including, without limitation, information requested in a Permit application) for the purpose of misleading a District employee or agent, or a member of the District Police Force in the conduct of his official duties.

Section 2.12. Disorderly Conduct.

(a) A Person commits the offense of disorderly conduct when he knowingly:

(1) Does any act in such unreasonable manner as to alarm or disturb another and to provoke a breach of the peace; or

(2) Makes or causes to be made any excessively loud or unreasonable noise which disturbs the peace. For purposes of this subsection 2.12(b), excessively loud or unreasonable noise is defined as noise inconsistent with or not attendant to appropriate and customary park and recreational activities, considering the nature and purpose of the actor's conduct, location, time of day or night, and other factors that would govern the conduct of a reasonably prudent person under the circumstances. This section shall include, without limitation, the loud or amplified playing of any type of audio equipment, noisemaker, musical instrument, or sound equipment. This section shall not apply to the playing of any musical instrument, public speaking, or the amplification thereof, in conjunction with activities conducted, sponsored or authorized by the District; or

(3) Uses obscene or abusive language or gestures, or threatens violence or injury to the person or property of others, in a manner intended and likely to incite or

produce an immediate breach of the peace or violent or disorderly response; or,

(4) Congregates with other Persons on District Property with the intent to restrict vehicular or pedestrian traffic or with the intent to restrict the free ingress to egress from District Property and fails to comply with a lawful order of the District Police Force to disperse.

(5) Engages in any gang related activity.

Section 2.13. Display of Permit or Pass. Every Person shall produce or display a Permit or pass when requested to do so by any authorized Personnel for the purpose of enforcing compliance with any federal, state, local, or District law, ordinance, rule, or regulation, when such Permit or pass is required to engage in an activity on District Property.

Section 2.14. Dumping, Pollution, Sanitation, and Litter.

(a) No Person shall litter, cast, throw, drop, leave, scatter, place, pile, or otherwise dump, leave, or deposit in any manner any kind of dirt, rubbish, placard, handbill, pamphlet, circular, book, notice, paper of any kind, ashes, garbage, waste material, snow, ice, or other substance, whether liquid or solid, or any other refuse in or upon District Property except as specifically permitted by the District. Provided, however, that paper, glass, cans, garbage and other refuse resulting from picnics or other lawful use of District Property may and shall be deposited in receptacles provided by the District for that purpose. Where receptacles are not provided, are missing, or are full to capacity, all such garbage, refuse, or other material shall be carried away from the area of use by the Person responsible for its creation and presence, and properly disposed of elsewhere.

(b) No Person shall spit upon District Property.

(c) No Person shall urinate or defecate on District Property other than in toilets in rest room facilities expressly provided for such purposes.

(d) No Person shall drain refuse from a trailer or other Vehicle on District Property.

(e) No Person shall bathe or wash himself or food, clothing, dishes, or other property at water outlets, fixtures or pools on District Property, except at those areas designated by the District for such use.

(f) No Person shall pollute or contaminate District Property or District Waters.

(g) No Person shall dispose of fish remains on District Property, or in District Waters within 200 feet of boat docks or designated swimming beaches and areas, or within any park area of the District except as permitted by the District.

(h) No Person shall dispose of human or animal waste on District Property except at designated locations or in fixtures provided for that purpose.

(i) Any Person violating this section may be assessed the cost of removing any such improperly deposited substance or material and such charge shall be in addition to and not in lieu of any other penalties provided for in this Ordinance or applicable federal, state, local, and/or District laws, ordinances, rules, and regulations.

Section 2.15. Erection of Structure/Wires. No Person shall construct, build, erect, or otherwise place any building, tent, stand, scaffold, platform or other structure of whatever kind, whether stationary or moveable and whether permanent or temporary in character, or construct, run, string, or otherwise place any electrical wire, conduit or pipe, or any public service or private utility, into, upon, above, or across or beneath District Property, unless a Permit, license, or contract therefor has first been obtained from the District.

Section 2.16. Fairs and Special Events: Sale and Distribution of Merchandise; Soliciting Contributions. No Person shall sell and/or distribute merchandise or printed or written materials or solicit contributions, votes or signatures during fairs or special events conducted or sponsored by the District except at a fixed location designated by the District and unless a Permit therefor has first been obtained from the District in accordance with Chapter V of this Ordinance. The District shall allocate space at the fixed location to applicants on a first-come, first-served basis until no more space remains available.

Section 2.17. Fires.

(a) No Person shall light, maintain, or make use of any fire on District Property, except at such places and at such times as the District may designate for such purpose and under such rules as may be prescribed by the District.

(b) No fire shall ever be left unattended. Every fire shall be under the continuous care and direction of a competent adult from the time it is kindled until the time it is completely extinguished. All fires must be properly and completely extinguished prior to any Person leaving the site of the fire.

(c) No Person shall throw or otherwise discard lighted or smoldering material in any manner that threatens, causes damage to, or results in the burning of District property or park resources, or creates a safety hazard.

Section 2.18. Fishing.

(a) No Person shall fish or otherwise take aquatic life from District Waters except in areas designated by the District for such purposes.

(b) Every Person fishing in District Waters shall comply with all applicable federal, state, local, and District laws, ordinances, rules, and regulations including, without limitation, conservation laws and licensing requirements.

(c) Fishing in District Waters shall be conducted by means of a hook and line, with the rod or line being closely attended. No Person shall use drugs, poisons, explosives, electricity, or missiles of any kind to fish in District Waters.

(d) No Person shall dig, scratch, or otherwise disturb District Property in order to locate or take bait.

(e) Every Person shall carefully and immediately return to the water from which it was taken any fish that does not conform to size or species restrictions imposed by any applicable federal, state, local or District law, ordinance, rule or regulation, or that the Person chooses not to keep.

(f) The provisions of this section apply to ice fishing.

Section 2.19. Gambling and Games of Chance. No Person shall play or engage in selling fortunes or futures, games of chance, or in any other device or game of chance, hazard or skill, either as bookmaker, dealer, player or otherwise, for the purpose of gaming or gambling for money or other valuable things on District Property, except at a fair, carnival, or other organized event conducted, sponsored or authorized by the District.

Section 2.20. Hunting or Trapping. No Person shall hunt or trap, nor bring any device for hunting or trapping into or onto District Property or District Waters.

Section 2.21. Interference with Other Users.

(a) No Person shall walk, act, or conduct himself upon any portion of District Property designated for a particular game, sport, event, amusement or other use in such a way as to interfere with the use of such portion by other Persons who are properly using the same for the particular sport, event, game, amusement or other use for which it has been designated.

(b) No Person shall unreasonably disturb or interfere with any Person occupying an area or participating in any activity on District Property under the authority of a Permit.

(c) No Person shall engage in any activity on District Property in a manner calculated or which is reasonably likely to endanger, injure, or damage Persons or property in any way.

Section 2.22. Loitering in District Buildings. No Person shall loiter or remain in any District building or facility in such a manner that: (1) unreasonably obstructs the usual use of entrances, hallways, corridors, stairways, or rooms designated for specific purposes; (2) impedes or disrupts the performance of official duties by District employees; or, (3) prevents the general public from obtaining the administrative or recreational services provided in the building or facility in a timely manner, after being requested to leave by any authorized Personnel or where the District has posted a sign or signs that prohibit loitering.

Section 2.23. Misappropriation of Property.

(a) No Person shall knowingly obtain or exercise unauthorized control over the property of another.

(b) No Person shall knowingly obtain by deception control over property of another.

(c) No Person shall knowingly obtain by threat control over property of another.

(d) No Person shall knowingly obtain control over stolen property knowing the property to have been stolen or under such circumstances as would reasonably induce him to believe that the property was stolen, where he:

(1) Intends to deprive the owner permanently of the use or benefit of the property; or,

(2) Knowingly uses, conceals, or abandons the property in such a manner as to deprive the owner permanently of such use or benefit; or,

(3) Uses, conceals, or abandons the property knowing such use, concealment, or abandonment probably will deprive the owner permanently of such use or benefit.

Section 2.24. Mob Action.

(a) No Person shall collect with other Persons, in bodies or in crowds of two (2) or more Persons without authority of law, for unlawful purposes or any purpose of disturbance or obstruction of the lawful activities of other Persons or otherwise disturb, obstruct, or interfere unreasonably with the lawful activities of other Persons using District Property in a manner which creates immediate violence or breach of the peace or threat thereof or endangers the person or property of others.

(b) No Person shall knowingly commit an act or engage in conduct that urges or incites other Persons to riot, engage in immediate violence or lawlessness, or commit any unlawful act.

(c) No Person shall organize, promote, encourage, or otherwise participate in a riot or other breach of the peace involving crowds of two (2) or more Persons gathered, without authority of law, for unlawful purposes or any purpose of disturbance or obstruction of the lawful activities of other Persons.

Section 2.25. Parades, Public Assemblies or Meetings.

(a) Public parades, processions, theatrical or dramatic presentations, meetings, assemblies, gatherings, and demonstrations, are permitted on District Property provided that where the number of participants is reasonably expected to exceed twelve (12) or more persons and/or vehicles, a Permit therefor must first be obtained from the District in accordance with Chapter V of this Ordinance.

(b) This section shall not apply to students going to and from school classes or participating in educational activities under the immediate direction and supervision of school authorities or their agents, a governmental agency acting within the scope of its functions, or normal or scheduled District programs or activities.

Section 2.26. Posting Printed or Written Material In Designated Area.

(a) The District shall designate an area for the posting of printed or written public information material ("Community Bulletin Board").

(b) No Person shall post, place, display, or cause to be posted, placed, or displayed any printed or written material on the Community Bulletin Board without presenting the material to the District. The District shall stamp and date the material as received, and post the material, space permitting, on the Community Bulletin Board unless the said material is obscene as defined in 720 ILCS 5/11-20. The material may remain posted for a period not to exceed one (1) week after which a Person may resubmit his public information notice for posting, space permitting.

(c) Space on the Community Bulletin Board shall be allocated on a first-come, first-served basis, except that the District's own printed or written public information may be given priority. The printed or written material shall be no larger than 8 1/2 inches x 11 inches and only one copy of each public information notice shall be posted.

(d) The District may remove printed or written material that has not been posted in accordance with this Section. The Person responsible for said posting shall be liable for the cost incurred in the removal thereof. The provisions of the Illinois Parental Responsibility Law (740 ILCS 115/1 *et seq.*) are specifically incorporated in this Ordinance by reference for purposes of this section.

Section 2.27. Posting Printed or Written Material On Public Places or Objects.

(a) Except as provided in Section 2.26 of this Ordinance, no Person shall paint, write on, or in any way mark or deface, or post or otherwise affix, any printed or written words, symbols, materials, or other marks to or upon District Property or any thing or object located on District Property.

(b) The District may remove any printed or written word, symbol, material, or other mark found posted or otherwise affixed upon any District Property or any thing or object located on District Property contrary to the provisions of this Section. The Person responsible for any such defacing, writing, or posting shall be liable for the cost incurred in the removal thereof. The provisions of the Illinois Parental Responsibility Law (740 ILCS 115/1 *et seq.*) are specifically incorporated in this Ordinance by reference for purposes of this section.

Section 2.28. Protection of Animals.

(a) No Person shall hunt, pursue, hurt, molest, wound, kill, trap, catch, poison, abuse, chase, shoot, touch, throw or propel objects at, endanger in any way, remove or cause to be removed, have in his possession, or release or cause to be released, any Wildlife on or upon District Property.

(b) No Person shall give or offer to any Wildlife any harmful, poisonous, or noxious substance on or upon District Property.

(c) No Person shall touch, tease, frighten, disturb, or otherwise intentionally interfere with any Wildlife while feeding, nesting, breeding, sleeping, resting, flying or otherwise moving, conducting or participating in any activity on or upon District Property.

(d) No Person shall molest, touch, throw or propel object at, destroy, dig up, crush, shake, or in any way tamper with or damage the nest, lair, den, burrow, or home of any Wildlife found on or upon District Property.

Section 2.29. Protection of Property.

(a) No Person shall mark, carve, bend, cut, paint, deface, affix any sticker or sign to, break down, destroy, damage, alter, change, sever, uproot, dig, excavate or otherwise remove, or attach or suspend any rope, wire, or other material or contrivance to, on, or from, District Property or any thing or object on or upon District Property, or otherwise take, damage or destroy such Property, thing or object unless a Permit, license or contract therefor has first been obtained from the District.

(b) No Person shall climb upon, walk on, hang from or stand or sit on, any plant, fence, structure, or other District Property of any kind except such benches or other property designated or customarily used for such purposes, or recreational equipment installed for such purposes.

(c) No Person shall bring into, throw, cast, drop, deposit, or otherwise leave or lay down any smoke bomb, stink bomb, or other offensive smelling compound on District Property.

(d) No Person shall bring any plant or portion of a plant or plant product onto District Property.

(e) The District may give rewards to the Person(s) (other than District employees or agents, or members of the District Police Force) who furnish information to the District, directly resulting in the arrest and conviction of any Person who unlawfully takes, damages, or destroys District Property. All claims for said reward must be made to the District within thirty (30) days after conviction and the District shall be the sole judge of any dispute arising over a reward, if any, and the Person(s) entitled to share therein. The District's decision on any matter connected with the reward shall be final, conclusive, and binding and shall not be subject to judicial review.

Section 2.30. Public Indecency.

(a) No Person shall perform or commit any of the following acts on District Property:

(1) An act of sexual penetration or sexual conduct as defined in 720 ILCS 5/12-12; or,

(2) A lewd exposure of the body done with intent to arouse or to satisfy the sexual desire of the Person.

(b) No Person shall exhibit, sell, give away, offer to sell or give away, display or hold or place in such a manner as to be open to public view any obscene book, pamphlet, drawing, picture, photograph, model, cast, instrument, or any other obscene article while on or upon District Property. For purposes of this subsection, obscene shall have the meaning ascribed to it in 720 ILCS 5/11-20.

Section 2.31. Reporting Accidents. A Person involved in an incident on District Property resulting in personal injury or property damage, other than an accident reportable under section 3.08 of this Ordinance, shall report the incident to any authorized Personnel within twenty-four (24) hours after the incident.

Section 2.32. Restricted Areas.

(a) No Person shall enter or remain in any building or portion of District Property where Persons are prohibited by the District from entering, or, except as provided in Section 2.34(c) of this Ordinance, where use is restricted to Persons of the opposite sex as indicated by a sign or notice posted by the District.

(b) No Person shall enter or remain in any District Property when it is closed to the public.

(c) No Person shall enter any District Property which is reserved or scheduled for a specific group or activity, unless such Person is invited by the individual, group, or agency responsible for such activity and, if applicable, such Person has paid all appropriate admission and/or registration fees.

Section 2.33. Restrictions Applicable to Specific Recreational Activities.

(a) Golf. No Person shall play or practice golf on District Property, except when involved in an established golf class under the supervision and direction of the District, or in an area designated for golf and the Person has satisfied all requisites before playing or practicing, including without limitation the paying of appropriate fees.

(b) Baseball and Softball Playing.

(1) No Person shall engage in softball or baseball games except in those parks which have established diamonds and backstops constructed for that purpose, or such other areas as may be specifically designated by the District;

(2) In those parks having established softball or baseball diamonds, participation in softball or baseball in areas other than established diamonds is limited in accordance with signs or notices posted by the District;

(3) In those parks having established softball or baseball diamonds, the type of recreation on said diamonds shall be in accordance with posted signs or notices posted by the District.

(c) Picnics.

(1) Picnics requiring fires shall be held only in those areas where fireplaces, stoves, grills, or pits have been provided for that purpose and upon issuance of a Permit by the District in accordance with Chapter V of this Ordinance;

(2) No group of Persons exceeding twelve (12) in number shall picnic on District Property unless a Permit therefor has first been obtained from the District in accordance with Chapter V of this Ordinance. The District may designate areas for preparing, consuming, and dispensing food, beverages and other products. Persons holding a Permit and dispensing any of such products may do so only in the area designated in the Permit. In the event the dispensing of the permitted products is by sale, the Person must also comply with Section 2.09 of this Ordinance. No Person may dispense, prepare, consume, sell or otherwise use products, items or things otherwise prohibited in this Ordinance or any other federal state, local, or District law, rule, regulation or ordinance.

(d) Classes and Camps. No Person shall bring or cause to be brought onto District Property any class, play class, day camp, or similar organized group activity of any kind unless a Permit allowing such use or activity has first been obtained from the District in accordance with Chapter V of this Ordinance.

(e) Tournaments, Leagues, or Other Organized Recreational Activities. No Person shall utilize any District Property, including without limitation playing fields and other District facilities, for tournaments, leagues, or other organized recreational activities and outings unless a Permit allowing such use or activity has first been obtained from the District in accordance with Chapter V of this Ordinance.

(f) This section does not apply to normal or scheduled District programs or activities. Where a conflict between normal or scheduled District programs or activities and a requested activity occurs, District programs and activities shall take precedence.

Section 2.34. Rest Rooms, Washrooms and Locker Rooms.

(a) Every Person shall cooperate in maintaining rest rooms, washrooms and locker rooms in a neat and sanitary condition.

(b) No Person shall deposit objects of any kind in the toilets or plumbing fixtures of a rest room, washroom facility or locker room.

(c) Children 5 years of age and up may not use rest rooms, washrooms and locker rooms designated for the opposite sex when a family locker room is available.

(d) Children 8 years of age and up may not use rest rooms, washrooms and locker rooms designated for the opposite sex.

(e) Individuals may not use restrooms, washrooms and locker rooms designated for

families.

(f) No Person shall use any camera, video recorder or other device to record or transmit visual image(s) in or from any rest room, washroom facility or locker room of the District.

Section 2.35. Rollerskates, Skateboards, and Other Similar Objects. No Person using rollerskates, rollerblades, skateboards, rollerskis, coasting vehicles, or similar devices shall interfere with pedestrian use of sidewalks or Vehicle use of the streets, or otherwise act negligently, recklessly or without due caution, or in any manner so as to endanger any Person or property nor use same where such use has been posted as prohibited.

Section 2.36. Selling or Distributing Printed or Written Material.

(a) The distribution of printed or written material available without cost or donation is permitted on District Property.

(b) The sale or distribution for donation of printed or written material is permitted on District Property provided that a Permit therefor has first been obtained from the District in accordance with Chapter V of this Ordinance.

(c) Any Person engaged in the sale or distribution of printed or written materials under this Section 2.36 shall not obstruct or impede pedestrians or Vehicles, harass park visitors with physical contact or persistent demands, misrepresent the affiliations of those engaged in such activities, misrepresent whether the materials are available without cost or donation, or interfere, interrupt, or engage in conduct incompatible with the purpose of any program, activity, function, and/or special event conducted or sponsored by the District.

Section 2.37. Sledding, Ice Skating, and Snowmobiling.

(a) No Person shall skate, sled, toboggan, innertube, ski, slide, or engage in similar activities on District Property except at such places and at such times as the District may designate for such purposes.

(b) No Person shall engage in any such activity in a reckless manner that endangers themselves or others or at a speed greater than is safe and proper under the circumstances.

(c) No Person shall tow, push, pull, or otherwise propel another Person on skis, sled, or other sliding device by use of any Vehicle on District Property.

(d) No Person shall drive, ride, or otherwise operate a snowmobile on District Property. For purposes of this subsection, a snowmobile shall be defined as any self-propelled vehicle intended for travel primarily on snow, driven by a track or tracks in contact with the snow, and steered by ski or skis in contact with the snow.

Section 2.38. Sleeping on District Property. Except as permitted in Section 2.07 of this Ordinance, no Person shall sleep on benches, sidewalks, parking lots, picnic grounds or tables,

playgrounds or playground equipment, stairways or doorways of District buildings or other District Property so as to unreasonably obstruct or hinder the movement of other Persons or the use of facilities.

Section 2.39. Smoking. Smoking or any use of a tobacco product is prohibited in all District buildings, facilities and Vehicles, except in designated areas of the Chevy Chase Country Club. Smoking is also prohibited in all wooded areas on District Property and within 100 feet of any point on a soccer, baseball, or football field, tennis court, or basketball court.

Section 2.40. Swimming. No Person shall bathe, swim, wade, float, splash, or otherwise enter District Waters except at such times and places and in compliance with all policies, rules and regulations as the District may designate for such activities.

Section 2.41. Weapons and Firearms.

- (a) No Person shall use, fire, set-off or otherwise cause to explode, discharge or burn, or throw onto or while on District Property any weapon or Firearm, as defined in Section 2.41(c), including but not limited to those weapons and Firearms described in 720 ILCS 5.24-1 *et seq.*
- (b) No Person shall carry or have in his possession any weapon or Firearm on District Property, except as otherwise preempted by the Firearm Owners Identification Card Act (430 ILCS 65/13.1) and the Firearm Concealed Carry Act (P.A. 98-0063) as set forth in Section 2.41(c) of this Ordinance.
- (c) For the purposes of this Section 2.41(c), the following terms shall apply in accordance with the Firearm Owners Identification Card Act (430 ILCS 65/13.1) and the Firearm Concealed Carry Act (P.A. 98-0063).

“Concealed Firearms” shall mean loaded or unloaded Handgun(s) carried on or about a Person completely or mostly concealed from view of the public or on or about a Person within a vehicle.

“Firearm” means any device, by whatever name known, which is designed to expel a projectile or projectiles by the action of an explosion, expansion of gas or escape of gas; excluding however:

- (1) Any pneumatic gun, spring gun, paint ball gun, or B-B gun which expels a single globular projectile not exceeding .18 inch in diameter or which has a maximum muzzle velocity of less than 700 feet per second;
- (2) Any pneumatic gun, spring gun, paint ball gun, or B-B gun which expels breakable paint balls containing washable marking colors;
- (3) Any device used exclusively for signaling or safety and required or recommended by the United States Coast Guard or the Interstate Commerce Commission.

- (4) Any device used exclusively for the firing of stud cartridges, explosive rivets or similar industrial ammunition; and
 - (5) An antique firearm (other than a machine-gun) which, although designed as a weapon, the Department of State Police finds by reason of the date of its manufacture, value, design, and other characteristics is primarily a collector's item and is not likely to be used as a weapon.
- (d) "Handgun" shall mean any device which is designed to expel a projectile or projectiles by the action of an explosion, expansion of gas, or escape of gas that is designed to be held and fired by the use of a single hand. A "Handgun" does not include a stun gun or taser, a machine gun, a short barreled rifle, or shotgun as these weapons are defined in the Illinois Criminal Code. A Handgun also does not include any pneumatic gun, spring gun, paint ball gun or B-B gun which expels a single projectile not exceeding .18 inch in diameter, or which has a maximum muzzle velocity of less than 700 feet per second, or which expels breakable paint balls containing washable marking colors. A Handgun is one type of Firearm.
- (e) "Licensee" shall mean a Person who has a license from the Illinois Department of State Police to carry a Concealed Firearm.

Except as provided herein, no Person may knowingly carry any Firearm in the following locations:

- (a) **Park District Building:** Firearms are prohibited in any building or portion of a building under the control of the District.
- (b) **Pre-school/Child Care Facility:** Firearms are prohibited in or on any District Property under the control of a pre-school or child care facility, including any room or portion of a building under the control of a pre-school or child care facility.
- (c) **Gathering Requiring Permit:** Except as provided herein, Firearms are prohibited at any public gathering or special event conducted on District Property that is open to the public but requires the issuance of a Permit from the District or other body. A Licensee is exempted from the section 2.41(c) if the Licensee is carrying a Firearm through a public gathering in order to access his or her residence, place of business or vehicle.
- (d) **Playgrounds:** Firearms are prohibited on all District playgrounds.
- (e) **Public Parks, Athletic Fields/Facilities:** All Firearms are prohibited in any public park, athletic field, real property or athletic facility owned or under the control of the District.
 - i. **Trail/Bikeway:** A Licensee is exempted from this Section 2.41(e) if the Person is carrying a Concealed Firearm while on a District trail or bikeway if only a portion of the trail or bikeway includes a public park.

- (f) **School Property:** Firearms are prohibited in District-sponsored programs or activities occurring a building, real property, and parking areas owned or under the control of a public or private elementary or secondary school, community college or university.
- (g) **Transportation:** Firearms are prohibited on any bus, train, or other form of transportation paid for in whole or in part with District funds, and any building, real property, and parking area under the control of a public transportation facility paid for in whole or in part with public funds.
- (h) **Event that Involves Sale of Liquor:** Firearms are prohibited in any District Property that has been issued a “Special Event Retailer’s license” as defined in Section 1-3.19.1 of the Liquor Control Act, during the time designed for the sale of alcohol by the Special Event Retailer’s license, or a “Special use permit license” as defined in subsection (q) of Section 5-1 of the Liquor Control Act during the time designated for the sale of alcohol by the Special use permit license.
- (i) **Parking Lots:** Except as provided herein, a Person is prohibited from carrying a Firearm in any District parking lot. A Licensee may carry a Concealed Firearm on or about his or her person within a vehicle into a parking area on District Property and may store a Concealed Firearm or ammunition concealed in a case within a locked vehicle or locked container out of plain view within the vehicle in a the parking area. A Licensee may carry a Concealed Firearm in the immediate area surrounding his or her vehicle within a prohibited parking lot area on District Property only for the limited purpose of storing or retrieving a Concealed Firearm within the vehicle’s trunk, if the Licensee ensures that the Concealed Firearm is unloaded prior to exiting the vehicle. The term “case” as used above includes a glove compartment or console that completely encloses the Concealed Firearm or ammunition, the trunk of the vehicle, or a Firearm carrying box, shipping box or other container.

A licensee is also permitted to carry a Concealed Firearm upon his or her person while he or she is traveling along a public right of way that touches or crosses any District owned or controlled premises, if the Concealed Firearm is carried on his or her person in accordance with the provisions of the Firearm Concealed Carry Act.

CHAPTER III - MOTORIZED VEHICLES, PARKING, AND TRAFFIC CONTROL

Section 3.01. All-Terrain Vehicles. No Person shall drive, ride, or otherwise operate an all-terrain Vehicle on District Property. For purposes of this section, an all-terrain Vehicle shall be defined as any motorized off-highway device 50 inches or less in width, having a manufacturer's dry weight of 600 pounds or less, travelling on three (3) or more low-pressure tires, designed with a seat or saddle for operator use, and handlebars or steering wheel for steering control.

Section 3.02. Bicycles.

(a) When two (2) or more Persons in a group are operating bicycles on District Property, they shall not ride abreast, but shall ride in single file.

(b) No Person operating a bicycle on District Property shall cling or attach himself or his bicycle to any other moving Vehicle.

(c) The operator of a bicycle emerging from an alley, driveway or building on District Property shall, upon approaching a sidewalk or the sidewalk area extending across any alley or driveway, yield the right-of-way to all pedestrians approaching on said sidewalk or sidewalk area, and upon entering the roadway shall yield the right-of-way to all Vehicles approaching on said roadway.

(d) No Person operating a bicycle on District Property shall carry another Person on the same bicycle. This restriction does not apply to tandem bicycles equipped with two or more seats or saddles or an ordinary bicycle equipped with a seat or saddle for an infant or small child if used properly. In that event, there shall be only the number of Persons on the bicycle as there are seats or saddles.

(e) No Person shall operate a bicycle on District Property between 30 minutes after sunset and 30 minutes before sunrise, without a clear, white, properly lighted headlight, visible under normal atmospheric conditions from the front thereof for not less than 500 feet and firmly attached to the bicycle, and without a red reflector firmly attached to the bicycle, which is clearly visible in the headlight beam of an automobile for a distance of 500 feet to the rear of the bicycle.

(f) No Person shall operate a bicycle on District playgrounds, ball fields, tennis courts, or sidewalks except that children under the age of 4 years old riding three- or more-wheeled cycles may operate such cycles on sidewalks while under the supervision and control of an adult.

(g) No Person shall ride a bicycle on any District street or path where signs are posted prohibiting riding bicycles.

(h) Bicycles shall not, at any time, in any place, be indiscriminately parked on District Property in such manner as to interfere with pedestrian or vehicular traffic, or with Persons getting into or out of Vehicles. No Person shall leave a bicycle on District Property lying on the ground or paving or set against trees or otherwise in a place other than a bicycle rack when such is provided and there is space available. No Person shall move or in any manner interfere with, any bicycle which is properly parked on District Property, nor shall any Person interfere with, or, in any manner, hinder any Person from properly parking a bicycle.

(i) All bicycles, when operated on District roadways, shall be kept to the right and shall be operated as nearly as practicable to the right-hand edge of the roadway.

(j) No Person shall operate a bicycle on District Property unless the bicycle is

equipped with a signaling device (e.g. bell or horn), in good working order and audible at a distance of 100 feet when sounded.

(k) No Person shall operate a bicycle on District Property at a speed faster than is reasonable and proper under the circumstances, and every bicycle shall be operated with reasonable regard for the safety of the rider and of other Persons and property.

(l) Every Person operating a bicycle on District Property shall obey all federal, state, local, and District traffic laws, rules, and regulations applicable to motor Vehicles, except those provisions which by their nature can have no application to the operation of a bicycle and except as otherwise provided by this section.

Section 3.03. Change of Oil/Cleaning. No Person shall change the oil or grease of, or wash, clean or polish Vehicles on District Property, unless a Permit therefor has first been obtained from the District in accordance with Chapter V of this Ordinance.

Section 3.04. Commercial Vehicles.

(a) The term "commercial vehicles" as used in this section shall include, but not be limited to trucks, station wagons, vans, pickups, passenger cars, or other Vehicles when used in transporting Persons or movable property for a fee or profit, either as a direct charge to another Person, or otherwise, or used as incident to providing services to another Person, or used in connection with any business.

(b) All roadways on District Property shall be used for pleasure driving only. No Person, other than District employees, shall drive any truck, tractor or other commercial vehicle of any kind on District Property without first obtaining a contract therefor from the District.

(c) This section shall not apply to commercial vehicles making authorized deliveries to or performing authorized services for the District.

Section 3.05. Driving Areas. No motor Vehicle shall be driven or otherwise operated upon District Property except over and upon such roadways, parking lots, or other areas designated or marked by the District for use by motor Vehicles. A bicycle path shall not be deemed a roadway for the use of motor Vehicles under this section.

Section 3.06. Duty of Operator in Accidents. No Person shall leave the scene of a collision with another Vehicle, Person or property occurring on District Property, without giving his true name and residence address to the injured Person or any other Person or member of the District Police Force requesting same, and in the event no public officer is present, he must immediately report the occurrence to the nearest police station or police headquarters.

Section 3.07. Emergency Vehicles.

(a) For purposes of this section, emergency Vehicles shall include all ambulances, fire trucks, police, fire, and ranger cars, and other Vehicles used to protect the public health, safety, and welfare.

(b) The provisions of this chapter regulating the movement or parking of Vehicles on District Property shall not apply to the operator of any emergency Vehicle when responding to an emergency call or pursuing an actual or suspected violator of the law. However, such operator shall exercise extreme caution when on or approaching District Property including without limitation slowing down as necessary for safety, cautiously proceeding through traffic lights or stop signs, and having the Vehicle's warning system signals operating (e.g. siren, lights).

(c) During non-emergency times, when not responding to an emergency call or in the pursuit of an actual or suspected violator of the law, the operator of an emergency Vehicle shall obey the provisions of this Chapter.

(d) Every Person operating a Vehicle on District Property shall, at the immediate approach of an emergency Vehicle making use of its warning system signals, yield the right-of-way and shall stop, if possible, and pull to the side of the road and remain in such position until the emergency Vehicle has passed, unless otherwise directed by a member of the District Police Force.

Section 3.08. Enforcement of Traffic Regulations. No Person shall fail to obey any authorized Personnel who is directing traffic or enforcing sections of this Chapter on District Property.

Section 3.09. Fleeing or Attempting to Elude the District Police Force. No Person driving or otherwise operating a motor Vehicle on District Property shall willfully fail or refuse to obey a visual or audible signal by a member of the District Police Force to bring his Vehicle to a stop. The signal given by a member of the District Police Force may be by hand, voice, siren, or red or blue light. The member of the District Police Force giving such signal shall be in uniform or driving a Vehicle appropriately marked showing it to be an official District Police Force Vehicle.

Section 3.10. Gas and Smoke. No Person shall drive or otherwise operate a Vehicle on District Property which emits excessive noxious fumes or dense smoke.

Section 3.11. Hitchhiking. No Person shall solicit a ride nor stand in or near a roadway on District Property for the purpose of soliciting a ride from the operator of any Vehicle.

Section 3.12. Incorporation of State Statutes. In addition to the provisions of this Chapter, and to the extent not inconsistent therewith, no Person shall drive or otherwise operate a Vehicle or perform any act in any manner on District Property in violation of Chapters 11 and 12 of the Illinois Vehicle Code (625 ILCS 5/11-100 *et seq.* and 625 ILCS 5/12-100 *et seq.*) which provisions are specifically incorporated in this Ordinance by reference.

Section 3.13. Intoxicated Operators.

(a) No Person shall drive or otherwise operate nor attempt to drive or otherwise operate a Vehicle on District Property while under the influence of intoxicating liquor, drugs, or a combination of liquor and drugs.

(b) Upon trial for such offense, in addition to other evidence, evidence of the amount

of alcohol in the Person at the time of the act alleged, as shown by a chemical analysis of his breath, blood, urine, saliva, or other bodily substances, is admissible, and the result of such analysis shall give rise to the presumptions set forth in Section 11-501.2(b) of the Illinois Vehicle Code (625 ILCS 5/11-501.2(b)) which provision is specifically incorporated in this Ordinance by reference.

Section 3.14. Minibikes, Motorized Scooter and Trailbikes. No Person shall drive, ride, or otherwise operate any minibike, motorized scooter or trailbike on District Property. For purposes of this section, every motor Vehicle which is self-propelled by power obtained by the combustion of gasoline which is designed with a seat or a saddle for the use of the rider, and is designed to travel mostly off-road on not more than three (3) wheels shall be a minibike, motorized scooter or trailbike.

Section 3.15. Negligent Driving. No Person shall drive or otherwise operate a Vehicle on District Property negligently, recklessly or without due caution, or in any manner so as to endanger any Person or property. All Vehicles shall be driven or otherwise operated on the right side of any roadway open to travel, except when passing other Vehicles.

Section 3.16. Parking.

(a) No Person shall park a Vehicle on District Property in other than established or designated parking areas, and such shall be in accordance with the posted directions and markings or with the directions of any attendant who may be present.

(b) No Person shall park any Vehicle or allow any Vehicle to remain parked in any area of District Property beyond the normal closing hour of the park system, except when a different closing hour has been designated by the District for that area or unless permission therefor has first been obtained from the District. In no event shall any Vehicle except District Vehicles be parked on District Property later than 11:30 p.m., except with the approval of the District which approval shall automatically be deemed given in connection with activities conducted by the District.

(c) No Person shall stop, park, or place any Vehicle on District Property so as to obstruct or interfere with traffic or travel or endanger the public safety, and no Person shall stop, park, or place any Vehicle in any of the following places except when otherwise designated, or when necessary to avoid conflict with other traffic or when in compliance with the instructions of a member of the District Police Force: (1) on the left side of any roadway; (2) on parkways, lawn areas, and grounds; (3) in front of a public or private driveway; (4) within any intersection; (5) within any crosswalk; (6) within 20 feet of any intersection or crosswalk; (7) within 30 feet of any stop sign or traffic control signal; (8) on the roadway side of any Vehicle stopped or parked at the edge or curb of the roadway; (9) in a position to block another Vehicle lawfully parked; (10) on any sidewalk; (11) at any place where official signs or other markings prohibit parking, or where curbs have been painted yellow; (12) within 15 feet of a fire hydrant; (13) in a fire lane or within 8 feet of the entrance to a fire lane; (14) within 20 feet of the driveway entrance to any fire station and on the side of a street opposite the entrance to any fire station within 75 feet of such entrance (when properly sign-posted); (15) between a safety zone and the adjacent curb or within 30 feet of points on the curb immediately opposite the ends of a safety

zone, unless a different length is indicated by signs or markings; (16) alongside or opposite any street excavation or obstruction when stopping, standing, or parking would obstruct traffic; (17) upon any bridge or other elevated structure upon a roadway, or within a roadway tunnel; (18) on any railroad tracks or within 50 feet of the nearest rail of a railroad crossing; (19) on a controlled-access roadway; (20) in the area between roadways of a divided highway, including without limitation crossovers; and, (21) at any place or time where a permit or sticker is required by the District for parking unless the required permit or sticker has been obtained and is displayed on the Vehicle.

(d) No Person shall park a Vehicle upon any roadway or in any public off-street parking facility on District Property for any of the following purposes:

- (1) To display such Vehicle for sale; or,
- (2) To perform maintenance or repair of such Vehicle, except for repairs necessitated by an emergency; or,
- (3) To sell goods or services from such Vehicle.
- (4) To use for commuter train parking.
- (5) To park more than 10 minutes in the Preschool Loading Zone.

(e) The operator of an authorized emergency Vehicle, as defined in section 3.09 of this Ordinance, may park or stand irrespective of the provisions of this Ordinance.

(f) Every Person in whose name a Vehicle is registered pursuant to law and who leases such Vehicle to others, after receiving written notice of a violation of this Ordinance involving such Vehicle, shall upon request provide the District with a written statement of the name and address of the lessee at the time of such offense and the identifying number upon the registration plates and registration sticker or stickers of such Vehicle.

(g) No Person who is the lessor of a Vehicle pursuant to a written lease agreement shall be liable for the violation of any parking or standing regulation of this Ordinance involving such Vehicle during the period of the lease provided that upon the District's request received within 120 days after the violation occurred, the lessor provides within 60 days after such receipt the name and address of the lessee. The driver's license number may also be requested by the District if needed for enforcement of this Ordinance.

(h) Except as otherwise provided, every Vehicle stopped or parked upon a two-way roadway on District Property shall be stopped or parked with the right-hand wheels parallel to and within twelve (12) inches of the right-hand curb or as close as practicable to the right edge of the right-hand shoulder.

(i) No Person shall move a Vehicle not lawfully under his control into any such prohibited area or away from a curb such distance as is unlawful.

(j) Except as otherwise provided, every Vehicle stopped or parked upon a one-way roadway on District Property shall be so stopped or parked parallel to the curb or edge of the roadway, in the direction of authorized traffic movement, with its right-hand wheels within twelve (12) inches of the right-hand curb or as close as practicable to the right edge of the right-hand shoulder, or with its left-hand wheels within twelve (12) inches of the left-hand curb or as close as practicable to the left edge of the left-hand shoulder.

(k) Penalty Provisions for Parking Violations.

(1) Whenever any Vehicle shall have been parked in violation of any section of this Ordinance prohibiting or restricting vehicular standing or parking, the Person in whose name the Vehicle is registered with the Secretary of State of Illinois shall be prima facie responsible for the violation and subject to the penalty therefor.

(2) Whenever any Vehicle is parked in violation of any parking provision of this Ordinance, any law enforcement officer observing such violation may issue a parking violation notice, and serve the notice on the owner of the Vehicle by handing it to the operator of the Vehicle, if he is present, or by affixing it to the Vehicle in a conspicuous place. The issuer of the notice shall specify on the notice his identification number, the particular parking regulation allegedly violated, the make and state registration number of the cited Vehicle, and the place, date, time, and nature of the alleged violation and shall certify the correctness of the specified information by signing his name to the notice.

(3) A parking violation notice issued, signed, and served in accordance with this section, or a copy of such notice, shall be prima facie correct and shall be prima facie evidence of the correctness of the fact, shown therein. The notice or copy thereof shall be admissible in any subsequent administrative or legal proceeding.

(4) Any violation of the parking provisions of this Ordinance or any provision of the Illinois Motor Vehicle Code prohibiting or restricting vehicular standing or parking shall be a civil offense punishable by fine and tow.

(5) Any Person on whom a parking violation notice has been served shall within fourteen (14) days from the date of the notice either pay the indicated fine or, in the manner indicated on the notice, request a court hearing to contest the charge, violation, or violations.

(6) If no response is made in accordance with subsection (k)(5) of this section, the Clerk of the Circuit Court shall serve a second notice of violation, by first-class mail, postage prepaid, to the address of the registered owner of the cited Vehicle as recorded with the Secretary of State of Illinois. The notice shall specify the date of a violation, and make and state registration of the cited Vehicle, the Ordinance or Code provision violated, the applicable fine and penalty in an amount equal to the relevant fine to be paid by the final notice date or request for hearing. The final notice date for payment shall be 21 days from the initial due date.

(7) If the respondent requests a court hearing in person to contest the cited

violation or violations, the Clerk of the Circuit Court shall notify the respondent in writing of the time and place of the hearing.

(8) A notice sent pursuant to subsections (k)(6), and/or (7), shall state that failure to pay the indicated fine or failure to request a court hearing will constitute a debt due and owing the District, and as such may be collected in accordance with applicable law. Payment in full of any fine and/or penalty resulting from a standing or parking violation shall constitute a final disposition of that violation.

(9) The Clerk of the Circuit Court shall notify the County State's Attorney of each respondent who fails to make payment or who fails to request a court hearing pursuant to subsections (k)(6), (7), and/or (8). Upon being notified by the Clerk of the Circuit Court, the County State's Attorney shall institute a civil action against the respondent in an amount of the fine plus a penalty double the relevant fine and costs. Any action instituted and proceeding therein shall be conducted in accordance with the Rules of the Circuit Court of Cook County, the Civil Practice Act and the laws, rules and regulations of the State of Illinois.

Section 3.17. Riding Outside Vehicles.

(a) No Person shall ride upon the fenders, running boards, bumpers, hood, or any other exterior part of any Vehicle on District Property.

(b) No Person shall cling or attach himself, his Vehicle, or any other object, to any other Vehicle on District Property.

Section 3.18. Right of Way.

(a) Every operator of a Vehicle shall yield the right of way to a pedestrian at any marked crosswalk or within any unmarked crosswalk at any intersection on District Property.

(b) Every operator of a Vehicle shall exercise due care to avoid colliding with pedestrians upon any roadway on District Property, shall give warning to any pedestrian in the roadway by sounding the horn when necessary, and shall exercise proper precaution upon observing any child, confused Person, or disabled Person upon a roadway.

(c) Every pedestrian crossing at a roadway on District Property at any point other than within a marked crosswalk or within an unmarked crosswalk at any intersection shall yield the right of way to Vehicles upon the roadway.

(d) Except as otherwise provided herein, the operator of a Vehicle approaching an intersection on District Property shall yield the right-of-way to a Vehicle which has already entered the intersection from a different roadway. When two (2) Vehicles approach an unmarked intersection from different roadways at approximately the same time, the operator of the Vehicle on the left shall yield the right-of-way to the Vehicle on the right.

Section 3.19. Siren Devices. No Person shall sound any siren-sounding device or other type of

signaling device which makes unusually loud or unnecessary noise on District Property unless that Person is driving or operating an authorized emergency Vehicle, as defined under section 3.09, responding to an emergency call, or pursuing an actual or suspected violator of the law.

Section 3.20. Speeding.

Except as provided in Section 3.09(b) of this Ordinance:

(a) No Person shall drive or otherwise operate a Vehicle on District Property at a speed greater than is reasonable and safe under the circumstances, having due regard for traffic, pedestrians, weather conditions and the intended use of the roadway and at no time at a speed greater than 10 miles per hour.

(b) No Person shall drive or otherwise operate a Vehicle on District Property at a speed which endangers the safety of any Person or property.

Section 3.21. Traffic Signs and Signals.

(a) No Person shall fail to observe all traffic signs indicating speed, direction, caution, stopping, parking, crosswalk lanes, traffic lane markers, and any other sign posted by the District for safeguarding life and property.

(b) No Person shall deface, injure, move, or otherwise interfere with any traffic sign or signal on District Property.

Section 3.22. Unattended Motor Vehicles. No Person driving, operating, or otherwise in charge of a motor Vehicle on District Property shall permit it to stand unattended without first stopping the engine, locking the ignition and removing the keys. When the motor Vehicle is standing upon any perceptible grade, the Person shall set the parking brake thereon and turn the front wheels to the curb or side of the roadway.

Section 3.23. Unauthorized Use of Parking Places Reserved for Handicapped Persons.

(a) For purposes of this section, handicapped person means every natural person who is unable to walk 200 feet or more unassisted by another person or without the aid of a walker, crutches, braces, prosthetic device, or a wheelchair or without great difficulty or discomfort due to the following impairments: neurological, orthopedic, respiratory, cardiac, arthritic disorder, blindness, or the loss of function or absence of a limb or limbs.

(b) No Person shall park on District Property any motor Vehicle which is not bearing registration plates or decals issued to a handicapped person, pursuant to 625 ILCS 5/3-616, 11-1301.1, 11-1301.2, or to a disabled veteran pursuant to 625 5/3-609 of the Illinois Vehicle Code which provisions are specifically incorporated in this Ordinance by reference, as evidence that the Vehicle is operated by or for a handicapped person or disabled veteran, in any parking place, including without limitation any private or public off-street parking facility, specifically reserved by the District, by the posting of an official sign as designated under 625 ILCS 5/11-301, for motor Vehicles bearing such registration plates. Any motor Vehicle bearing a handicapped

license plate or a handicapped parking decal or device containing the international symbol of access issued to handicapped persons by any local authority, state, district, territory or foreign country shall be recognized by the District as a valid license plate or device and receive the same parking privileges as handicapped residents of this State.

(c) The District may remove or cause to be removed to the nearest garage or other place of safety any Vehicle parked within a stall or space reserved for use by the handicapped which does not display handicapped registration plates or a special decal or device as required by this section.

(d) Any Person found guilty of violating the provisions of this section shall be fined the current State of Illinois fine in addition to any costs or charges connected with the removal or storage of any motor Vehicle authorized under this section.

Section 3.24 Use of Electronic Personal Assistive Mobility Devices (EPAMD) in District Facilities and at District Parks.

(a) The Wheeling Park District authorizes persons with mobility impairments to use an EPAMD in District facilities and sites subject to the following restrictions:

(1) The operator of the device must be a person with a mobility impairment, and upon request by District officials, shall produce proof of such status within 24 hours;

(2) The device, if used in a facility or in a park, is allowed in any area of the facility or park in which the general public is allowed, with the exception of employee-only spaces, stairways, and identified hazardous areas;

(3) The device, if used in a facility, must be controlled by the operator. It:

a. may not exceed 4 mph;

b. shall be driven on the right side of the circulation route;

c. is prohibited from carrying another person on the frame, or any object on the frame that may make the EPAMD less stable;

d. must not be operated in a dangerous or reckless manner that jeopardizes the safety of the operator, District employees, or District participants.

(4) The device, if used in a park or out-of-doors, must be controlled by the operator. It:

a. may not be operated between dusk and dawn;

b. may not exceed 6 mph;

c. may not be driven into wet or ecologically sensitive areas which

are posted as prohibited areas by the Park District;

d. shall be driven on the right side of the circulation route;

e. is prohibited from carrying another person on the frame, or any object on the frame that may make the EPAMD less stable;

f. must not be operated in a dangerous or reckless manner that jeopardizes the safety of the operator, District employees, or District participants.

(5) The District accepts no responsibility for storage of the device.

(6) The District accepts no liability for damage to the device, or injury to the operator, whether caused by the operator, another visitor to a District facility or site, or any other circumstance.

(7) The District accepts no liability for damage caused by the operator of the device, or injury to others caused by the operator of the device.

(8) The District reserves the right to suspend the use of facilities or sites by the operator if doing so is in the best interests of the District and its participants.

(9) The District reserves the right to change, modify, or amend this policy at any time, as it would any other policy.

CHAPTER IV - PARK HOURS, CLOSING, AND GENERAL OPERATION POLICIES

Section 4.01. Hours.

(a) Except as otherwise provided in this Section 4.01, District Property shall be open to the public from sunrise in the morning until sunset in the evening of that same day and District Property shall be closed to the public from sunset each day until sunrise the following day. Lighted fields shall remain open to the public so long as the lights are illuminated.

(b) The Board may establish other hours during which District Property or any parts thereof shall be closed to the public. The Board may periodically revise these hours.

Section 4.02. Special Closings. The Board or the Director may close one or more District parks, buildings, and facilities or any part thereof to the public at any time and for any interval of time, either temporarily or at regular intervals, and either entirely or merely to certain uses, as deemed advisable and in the best interest of the public and District.

Section 4.03. Use of Closed Property Prohibited. No Person shall use, occupy, be in, or remain upon District Property or leave any personal property in or upon District Property which is closed to the public, or after closing hours, unless permission therefor has first been obtained from the District.

Section 4.04. Schedules, Fees, Rules, and Regulations. Time schedules for the operation of, and the activities to be conducted on, District Property and the amount of facility, Permit and program fees, may be reviewed and approved periodically by the Board. As permitted by law, fees charged non-residents of the District need not be the same as fees charged residents of the District. The Board may otherwise establish policies, rules and regulations for proper conduct by Persons using District Property. Specific policies, rules and regulations pertaining to District Property and programs may be posted at or on the applicable District Property and/or published in District program brochures or otherwise made available to the users of District Property, who shall be charged with actual knowledge thereof. All Persons shall abide by all District policies, rules and regulations and with the direct orders or requests of employees and agents of the District when using District Property.

Section 4.05. Admission/Identification. No Person shall enter into, be, or remain in or upon District Property without paying proper admission fees, without complying with registration requirements, if any, which may be established by the District, and without displaying the required admission identification. All admission identification cards, papers and tickets are non-transferable and must be individually registered, unless otherwise specifically noted thereon. A charge may be made by the District for replacing lost admission identification cards, papers and tickets.

Section 4.06. Lost, Found, and Abandoned Property.

(a) No Person shall abandon property on District Property.

(b) Property left unattended for longer than twenty-four (24) hours or unattended property that interferes with any park visitors' safety, orderly management of the park area, or presents a threat to park resources may be impounded or removed by the District at any time. The owner of such property shall be responsible and liable for all costs and expenses associated with the impounding, removal, storage, or other disposal of the property.

(c) Any Person finding lost or unattended property on District Property shall report such finding to the District as soon as is practicable. Whenever a District employee or agent finds lost or unattended property on District Property he shall report such find to his Division Head. The District will attempt to make every reasonable effort to locate the property's owner(s).

(d) Unattended property that has been impounded or property that has been found shall be stored for a minimum period of thirty (30) days. Unless claimed by the owner or an authorized agent thereof, the property may be claimed by the finder of such property unless the finder is an employee, officer, or agent of the District or Board. All property not claimed shall be disposed of as the District deems appropriate.

Section 4.07. Building Use. No Person shall use any District building or facility for an event or activity which is not conducted or sponsored by the District unless a Permit therefor has first been obtained from the District in accordance with Chapter V of this Ordinance and/or a license agreement has been executed with the District. All Persons using District buildings or facilities shall comply with the provisions of this Ordinance and with the provisions and conditions of the

Permit and/or license agreement and with all other applicable policies, rules, and regulations of the District regarding the use of District Property.

Section 4.08. Soccer Goal Safety and Education Policy.

I. INTRODUCTION AND IDENTIFICATION OF ACT

This Soccer Goal Safety and Education Policy (“Policy”) is adopted pursuant to the Illinois Movable Soccer Goal Safety Act, also known as Zach’s Law, Public Act 097-0234 (the “Act”). The Act requires Wheeling Park District to create a policy to outline how it will specifically address the safety issues associated with movable soccer goals.

II. DEFINITIONS

The following words shall have the following meanings when used in this Policy.

“Act” means the Illinois Movable Soccer Goal Safety Act, also known as Zach’s Law, Public Act 097-0234.

"Authorized Personnel" means Permitted Users and all District employees who have responsibility for or contact with Movable Soccer Goals.

“Board” means the Board of Commissioners of the District.

“District” means Wheeling Park District.

“Movable Soccer Goal(s)” means a freestanding structure consisting of at least 2 upright posts, a crossbar, and support bars that is designed: (1) to be used for the purposes of a soccer goal; (2) to be used without any form of support or restraint other than pegs, stakes, augers, counter-weights, or other types of temporary anchoring devices; and (3) to be able to be moved to different locations.

“Organization” means any unit of local government other than the District, and any school district, sporting club, soccer organization, religious organization, business, or other similar organization.

“Permitted User(s)” means an Organization and all of its employees, agents, coaches and volunteers that use Property for Soccer-Related Activities.

“Policy” means this Soccer Goal Safety and Education Policy.

“Property” means real property owned or leased by the District where Movable Soccer Goals are used.

“Safety Guidelines” mean the Guidelines for Safely Securing Movable Soccer Goals attached to this Policy as Attachment 1.

“Soccer-Related Activity” means use of Movable Soccer Goals on Property, including without limitation, soccer games, scrimmages, practices and the like.

III. MOVING AND SECURING MOVABLE SOCCER GOALS; WARNING LABELS

Prior to the commencement of the soccer season each year, the District will place and secure Movable Soccer Goals on its Property in accordance with the Safety Guidelines. Only the District shall be permitted to move any Movable Soccer Goal the District owns, installs, or places on its Property.

Thereafter, if a Movable Soccer Goal becomes unanchored or improperly secured, only Authorized Personnel shall be permitted to re-secure it in accordance with the Safety Guidelines.

A warning label such as the following shall be posted on all Movable Soccer Goals:

ONLY AUTHORIZED PERSONNEL MAY MOVE AND ANCHOR THIS GOAL. IF THIS GOAL IS NOT ANCHORED DOWN, DO NOT USE IT AND CONTACT WHEELING PARK DISTRICT. SERIOUS INJURY INCLUDING DEATH CAN OCCUR IF IT TIPS OVER.

IV. ROUTINE INSPECTIONS BY DISTRICT

The District shall routinely inspect all Movable Soccer Goals that the District has installed or placed onto its Property to verify that they are properly secured and document such inspection in writing.

V. PERMITTED USER INSPECTIONS, PLACEMENT IN NON-USE POSITION AND NOTICE TO PLAYERS

As a condition of the use of Property, before and after any Soccer-Related Activity, Permitted Users shall make a physical inspection of each Movable Soccer Goal to assure that the goal is secure in accordance with the Safety Guidelines. If any Movable Soccer Goal is not properly secured, the Permitted User shall secure the goal in accordance with the Safety Guidelines. If the Permitted User does not have the necessary equipment to secure the goal in accordance with the Safety Guidelines, the Permitted User shall place the goal in a non-use position by laying it forward onto its front bars and crossbar and shall immediately notify the District of the location of the goal.

As a condition of the use of Property and prior to the commencement of the soccer season each year, each Organization shall advise their players and the players’ parents and guardians that Movable Soccer Goals may not be moved and that any use of a Movable Soccer Goal that is inconsistent with Soccer-Related Activity is strictly prohibited, including without limitation, playing, climbing, or hanging on any part of the Movable Soccer Goal. According to the U.S. Consumer Product Safety Commission, these activities can result in serious injury, including death. A sample notice is attached hereto as Attachment 2.

VI. USE OF DISTRICT PROPERTY BY PERMITTED USERS

A copy of this Policy shall be provided to all Organizations using the Property for Soccer-Related Activity. Prior to using Property for Soccer-Related Activity, each Organization shall provide each of its Permitted Users with a copy of this Policy and shall require that each of its Permitted Users comply with all applicable provisions of this Policy.

VII. REMOVAL

At the conclusion of each soccer season, the District will either remove all Movable Soccer Goals that it has installed or otherwise placed on its Property and store such goals at a secure location or otherwise secure such goals on its Property by placing the goal frames face to face (front posts and crossbars facing toward each other) and securing them at each goalpost with a lock and chain; or locking and chaining the goals to a suitable fixed structure such as a permanent fence; or locking unused portable goals in a secure storage room after each use; or fully disassembling the goals for season storage.

VIII. ACQUISITION OF TIP-RESISTANT MOVABLE SOCCER GOALS

After the effective date of this Policy, the District will not purchase any Movable Soccer Goal unless it is tip resistant. A Movable Soccer Goal whose inside measurements are 6.5 to 8 feet high and 18 to 24 feet wide is not tip-resistant unless it conforms to the American Society for Testing and Materials (ASTM) standard F2673-08 for tip-resistant Movable Soccer Goals or is otherwise equipped with another design feature approved by the U.S. Consumer Product Safety Commission. Notwithstanding the foregoing provisions, the District may continue to use its existing goals in a manner consistent with this Policy.

IX. APPLICABILITY

If any provision of this Policy conflicts with any provision of the Act, the provisions of the Act shall prevail.

This Policy shall not create any new liability or increase any existing liability of the District, or any of its officers, employees, or agents, which exists under any other law, including but not limited to the Local Governmental and Governmental Employees Tort Immunity Act, 745 ILCS 10/1-101 *et seq.* Nor shall this Policy alter, diminish, restrict, cancel, or waive any defense or immunity of the District or any of its officers, employees, or agents, which exists under any other law, including but not limited to the Local Governmental and Governmental Employees Tort Immunity Act, 745 ILCS 10/1-101 *et seq.*

X. AVAILABILITY OF POLICY

All District employees who have responsibility for or contact with Movable Soccer Goals shall be advised of this Policy.

A copy of the Policy is available to all other employees and any member of the public by requesting a copy from Wheeling Park District, 333 W. Dundee Road, Wheeling, IL; telephone (847) 465-3333.

XI. AMENDMENTS

This Policy may be amended by the District at any time.

XI. EFFECTIVE DATE

This Policy becomes effective August 16, 2011.

ATTACHMENT 1

GUIDELINES FOR SAFELY SECURING MOVABLE SOCCER GOALS

According to the U.S. Consumer Product Safety Commission (CPSC), a properly anchored/counter-weighted movable soccer goal is much less likely to tip over. Accordingly, it is **IMPERATIVE** that **ALL** movable soccer goals are always anchored properly (*e.g.*, see Figure 2 below) and that they are secured to the ground (preferably at the rear of the goal), making sure the anchors are flush with the ground and clearly visible.

There are several different ways to secure a Movable Soccer Goal. The number and type of anchors to be used will depend on a number of factors, such as soil type, soil moisture content, and total goal weight. Each goal shall be secured in accordance with the appropriate anchoring system as set forth below.

In addition, warning labels required by the District's Soccer Goal Safety and Education Policy will be attached to each goal. Nets shall be secured to posts, crossbars, and backdrops with tape or Velcro straps at intervals of no less than one every four feet.

Illustrations and Recommendations according to the U.S. Consumer Product Safety Commission

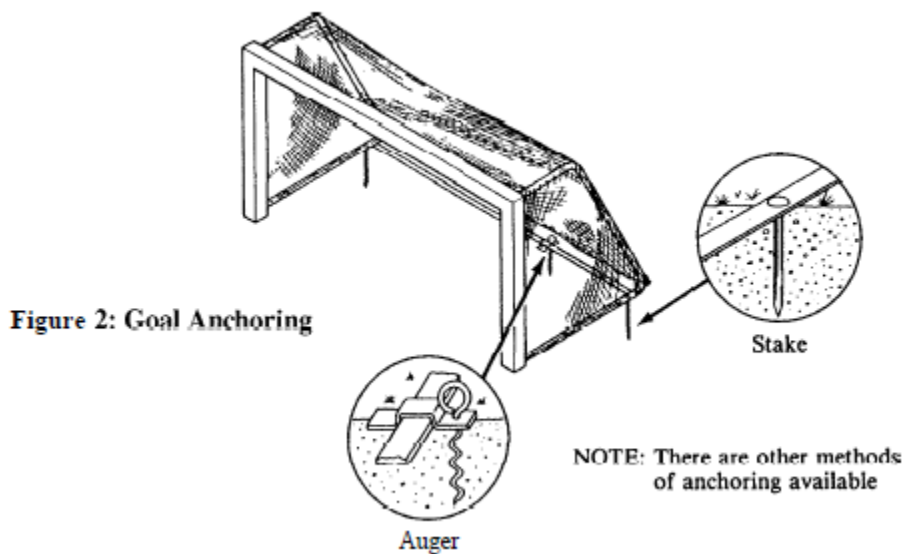

ATTACHMENT 1 - continued

Anchor Types

1. Auger style

This style anchor is “helical” shaped and is screwed into the ground. A flange is positioned over the ground shoes (bar) and rear ground shoe (bar) to secure them to the ground. A minimum of two auger-style anchors (one on each side of the goal) are recommended. More may be required, depending on the manufacturer’s specifications, the weight of the goal, and soil conditions.

Figure 3.1: Auger Style Anchor



2. Semi-permanent

This anchor type is usually comprised of two or more functional components. The main support requires a permanently secured base that is buried underground. One type (3.2a) of semi-permanent anchor connects the underground base to the soccer goal by means of 2 tethers. Another design (3.2b) utilizes a buried anchor tube with a threaded opening at ground level. The goal is positioned over the buried tube and the bolt is passed through the goal ground shoes (bar) and rear ground shoe (bar) and screwed into the threaded hole of the buried tube.

Figure 3.2a: Semipermanent Anchor

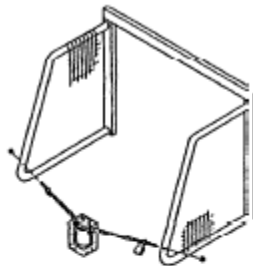
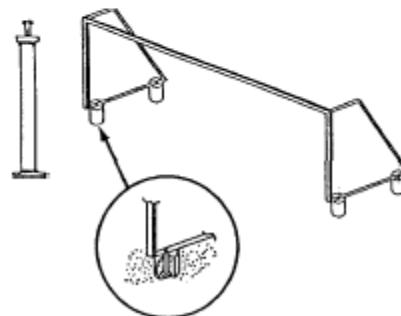

Figure 3.2b: Semipermanent Anchor



ATTACHMENT 1 - continued

3. Peg or Stake style (varying lengths) Anchor

Typically two to four pegs or stakes are used per goal (more for heavier goals) (Figure 3.3). The normal length of a peg or stake is approximately 10 inches (250mm). Care should be taken when installing pegs or stakes. Pegs or stakes should be driven into the ground with a sledge-hammer as far as possible and at an angle if possible, through available holes in the ground shoes (bar) and rear ground shoe (bar) to secure them to the ground. If the peg or stake is not flush with the ground, it should be clearly visible to persons playing near the soccer goal. Stakes with larger diameters or textured surfaces have greater holding capacity.

Figure 3.3: Peg or Stake Style Anchor

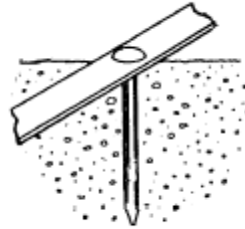

4. J-Hook Shaped Stake style

This style is used when holes are not pre-drilled into the ground shoes (bars) or rear ground shoe (bar) of the goal. Similar to the peg or stake style, this anchor is hammered, at an angle if possible, directly into the earth. The curved (top) position of this anchor fits over the goal member to secure it to the ground (Figure 3.4). Typically, two to four stakes of this type are recommended (per goal), depending on stake structure, manufacturers specifications, weight of goal, and soil conditions. Stakes with larger diameters or textured surfaces have greater holding capacity.

Figure 3.4: J-Hook Anchor

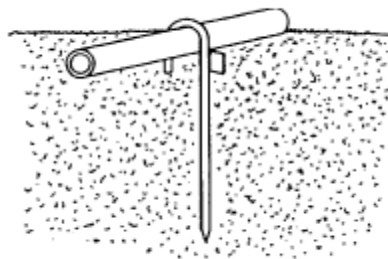

ATTACHMENT 1 - continued

5. Sandbags/Counterweights

Sandbags or other counterweights could be an effective alternative on hard surfaces, such as artificial turf, where the surface cannot be penetrated by a conventional anchor (i.e., an indoor practice facility) (Figure 3.5). The number of bags or weights needed will vary and must be adequate for the size and total weight of the goal being supported.

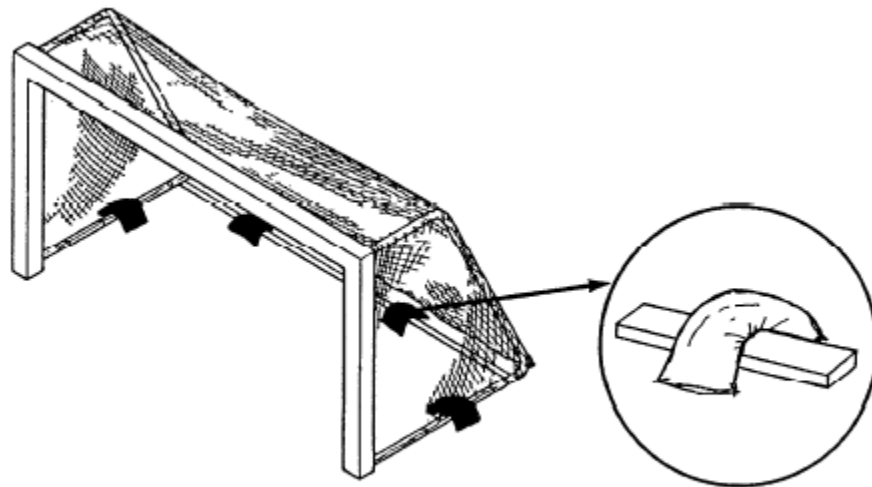
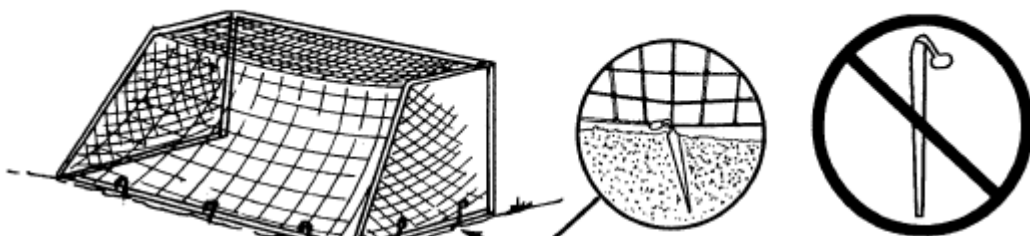

Figure 3.5: Sandbag Method of Anchoring

(Rear) Ground Bar/Shoe

6. Net Pegs

These tapered, metal stakes should be used to secure only the NET to the ground (Figure 3.6). Net pegs should NOT be used to anchor the movable soccer goal.



Net pegs should **never** be used to anchor a soccer goal

Figure 3.6: Net Pegs

ATTACHMENT 2

SAMPLE NOTICE

[INSERT DATE]

TO WHOM IT MAY CONCERN: All parents and guardians of soccer players:

One of our primary objectives is that children have safe recreation areas. To that end, soccer goals should remain securely anchored to the ground and nets firmly attached to the goals.

In an effort to keep the goals and nets secure and children safe, you are required to advise your children/soccer players and any other person accompanying you for whom you are responsible that the following is strictly prohibited: moving any soccer goals and any use of a soccer goal that is inconsistent with soccer-related activity, including without limitation, playing, climbing, or hanging on any part of the soccer goal. This especially applies to children climbing on or hanging from nets or goal frames. According to the U.S. Consumer Product Safety Commission, these activities can result in serious injury, including death.

If you observe any child inappropriately using a soccer goal or net, immediately and politely ask the child to stop. If the activity continues, please notify a coach or referee as soon as possible. Players violating this rule may be forced to sit out, at the coach's discretion.

Finally, if you see any soccer goal that is not anchored down or any net that is not firmly secured to the goal, please notify a coach or referee immediately.

Sincerely,

[INSERT NAME]

CHAPTER V - PERMITS AND OTHER AUTHORITY

Section 5.01. Permits.

(a) Permits may be granted upon proper application and approval where the applicable section of this Ordinance or any other District ordinance, policy, rule, or regulation provides for the issuing of a Permit in order to engage in a particular activity.

(b) Every Person requesting a Permit shall complete and file a written application with the Director, on forms provided by the District, and pay applicable application fees at the District's administrative offices located at 333 W. Dundee Road, Wheeling, Illinois. When received, the application shall be dated and stamped as received and a receipt issued to the applicant.

(c) Except as provided in subsection 5.01(c)(1), applications for Permits must be received by the District at least forty-eight (48) hours prior to the activity for which a Permit is sought.

(1) This application deadline shall not apply to applications for Permits under sections 2.02, 2.09, 2.33 and any other section of this Ordinance or any other District ordinance, rule, or regulation not involving the exercise of First Amendment rights. For such Permits, applications must be received by the District at least three (3) weeks prior to the requested activity.

(d) Except as provided in subsection 5.01(d)(6), the District shall issue the Permit without unreasonable delay unless:

(1) The proposed activity violates any federal, state, local, or District law, rule, or regulation; or,

(2) A prior application for a Permit for the same date, time, and location has been or will be granted and the activities authorized by that Permit do not reasonably allow multiple occupancy of that particular area; or,

(3) The proposed activity is of such a nature that it cannot reasonably be accommodated in the particular location applied for, considering, without limitation, the likelihood of such things as damage to park resources or facilities, damage to an environmentally sensitive or protected area's ecosystem, impairment of a protected area's atmosphere of peace and tranquility, unreasonable interference with District functions, buildings, facilities, operations, programs or activities, or unreasonable interference with the use or purpose of the District Property applied for; or,

(4) The proposed activity would substantially impair the operation or use of facilities or services of District concessionaires or contractors; or,

(5) The proposed activity would so dominate the use of District Property as to preclude other Persons from using and enjoying the park.

(6) This subsection 5.01(d) is not applicable to applications for commercial activity Permits under sections 2.09 and 2.16 of this Ordinance and Permits for alcohol under section 2.02. The District reserves the right to exercise its discretion in issuing Permits under sections 2.02, 2.09 and 2.16.

(e) The District shall have at least twenty-four (24) hours from the time of the application's receipt to review the application. However, for applications under section 2.16 of this Ordinance, the District shall have at least forty-eight (48) hours from the time of the application's receipt to review the application. For applications under sections 2.02, 2.09, 2.33 and any other section of this Ordinance or any other District ordinance, rule, or regulation not involving the exercise of First Amendment rights, the District shall have at least two (2) weeks from the time of the application's receipt to review the application. However, the District reserves the right to take additional time to review any application. If the District determines that it will exercise this right, it shall notify the applicant within twenty-four (24) hours after the District's receipt of the application.

(f) If the application is approved, the District shall issue a written Permit to the applicant. If the application is denied, the District shall issue to the applicant written reasons for denying the application.

(g) If an application is denied on the basis of a scheduling conflict or inappropriateness of the location, duration, or time of the activity, the District will make a reasonable effort to arrange an alternative that is acceptable to all parties. If an application under sections 2.08, 2.25 or 2.36 is denied, or the applicant is dissatisfied with such Permit as issued, he may appeal the decision to the Board within ten (10) days after the decision is rendered. If the Board rejects the appeal after full review, or if time for full review is not available, the applicant may appeal the decision to the appropriate state or federal court. All other decisions on the issuance of Permits by the District are final.

(h) Any Permit granted by the District may contain lawful prerequisites to the issuing of the Permit and restrictions on the conduct of the permitted activity including without limitation: general liability insurance coverage; an agreement to fully indemnify and hold the District harmless from any liability or costs resulting from the activity; a requirement that the Persons involved in the activity observe all federal, state, local, and District laws, rules, and regulations; time, duration, and location restrictions; restoration deposit; a written agreement by the applicant to fully restore any District Property soiled or damaged by the activity; and, any reasonable restriction necessary for the efficient and orderly contemporaneous administration of the activity, other activities with a Permit, and regular District uses, functions, programs, and activities.

(i) Any Person holding a valid Permit issued by the District for use of District Property shall take precedence for use of that District Property over any Person other than the District.

(j) The District may make necessary changes or place necessary additional restrictions on any Permit after it has been issued.

(k) Violation of the terms and conditions associated with the Permit may result in the suspension or revocation of the Permit.

(l) Except as provided in subsections 5.01(l)(1)(2), no Permit shall be issued for a period in excess of seven (7) consecutive days. A Permit may be extended for like periods of time upon a new application, unless another Person has requested use of the same location and multiple use of that location is not reasonably possible.

(1) This subsection shall not apply to Permits granted under section 2.09 of this Ordinance. For Permits granted under section 2.09, the District shall determine the length of time that a Permit will be valid.

(2) This subsection shall not apply to Permits granted under section 2.36 of this Ordinance for newsracks or newsstands. Such Permits granted under section 2.36 shall be issued for a period of six (6) months.

Section 5.02. Insurance and Hold Harmless Agreement.

(a) Except as provided in subsection 5.02(a)(1), every applicant for a Permit shall acquire general liability insurance to protect himself and the District from liability resulting from his use of District Property and provide proof of such insurance to the District before the District will issue a Permit to an otherwise valid applicant. The District must be named on such policy as additional insured. Where possible, an applicant may acquire a rider to the District's insurance policy at the applicant's cost and expense. Applicants should contact the District's administrative office for more information.

(1) For activities involving the exercise of First Amendment rights, including without limitation parades, public gatherings, speeches and rallies, this requirement may be waived by the District if the applicant can demonstrate that he or his organization cannot procure general liability insurance or that the cost of procuring such insurance or acquiring a rider to the District's insurance policy is prohibitive.

(b) Every applicant must execute and deliver to the Park District an agreement to indemnify and hold the District harmless from legal liability, property damage or injury to persons caused by the negligent or unlawful acts of the applicant or any member, volunteer, employee, agent, participant, or other Person associated with the applicant or his group or organization.

Section 5.03. Restoration Deposit.

(a) A restoration deposit may be required for any Permit. The District shall refund the deposit if the Person responsible for the activity cleans any refuse caused or left by the activity or the activity's participants and restores District Property to the condition it was in prior to the activity to the District's satisfaction. If the District is required to cleanup or restore District Property after the activity, the Person responsible for the activity shall reimburse the District for all costs and expenses associated with the cleanup and restoration. The cost of the cleanup and restoration shall be taken from the restoration deposit. If there are any funds remaining after the cleanup and restoration costs have been subtracted, they shall be returned to the appropriate Person. If the costs and expenses for the cleanup and restoration exceed the amount of the restoration deposit, the District reserves the right to pursue any and all legal options.

(b) If the restoration deposit would create a financial hardship for the applicant which the applicant can so demonstrate, the District may accept a written agreement to cleanup and restore District Property after the activity. If the applicant does not satisfactorily perform according to the agreement, the District reserves the right to pursue any and all legal options.

Section 5.04. Other Authority. Activities otherwise prohibited under this Ordinance, or any other District ordinance, policy, rule, or regulation may be conducted or engaged in by a Person, his agents and/or employees, if done in strict conformance with the provisions of an agreement with the District which has been duly authorized by the Board.

CHAPTER VI - ENFORCEMENT

Section 6.01. Police/Security Force.

(a) The District Police Force shall be the conservators of the peace on District Property, and shall be responsible for the enforcement of all federal, state, local, and District laws, rules, and regulations on District Property.

(b) The members of the District Police Force shall have the authority to eject from District Property, arrest, or issue citations to any Person who violates any applicable federal, state, local, or District law, rule, or regulation on District Property.

Section 6.02. Rules to be Obeyed. No Person shall violate or disobey any provision of this Ordinance or any other District ordinance, policy, rule or regulation regulating conduct or activities on District Property even though the same may not have been posted. No Person shall violate or disobey the directions or instructions contained in any notice or sign posted by the District relating to the use of District Property, or the directions or instructions of any member of the District Police Force, or any employee of the District seeking to enforce compliance with federal, state, local or District laws, rules, or regulations.

Section 6.03. Parties to Ordinance Violation.

(a) Every Person who commits, attempts to commit, conspires to commit, or aids or abets in the commission of any act in violation of this Ordinance or other ordinance, rule or regulation of the District, as a principal, agent, or accessory, shall be guilty of such offense, and every Person who falsely, fraudulently, forcibly or wilfully induces, causes, coerces, requires, permits, or directs another to violate any provision of this Ordinance is likewise guilty of such offense.

(b) Any Person who is the owner, registered owner, or Person in control of any animal, Vehicle or other property of any kind brought, placed, parked or allowed to remain on District Property in violation of this Ordinance or other District ordinance, rule, or regulation, shall be deemed prima facie responsible for such violation and shall be subject to the penalties provided herein.

(c) It is unlawful for the owner or any other Person employing or otherwise directing the operator of any Vehicle, to request or knowingly permit operation of any such Vehicle on District Property in any manner contrary to this Ordinance.

CHAPTER VII - PENALTIES

Section 7.01. Revocation of Privileges; Fine. Any Person violating or disobeying any section or part of this Ordinance, or any other District ordinance, policy, rule, or regulation, may be forthwith evicted from District Property, may have his admission rights to District Property terminated, revoked, forfeited or suspended for the remainder of the season, and/or may, upon conviction, be fined not more than \$500.00 for each offense.

Section 7.02. Restitution. In addition to, or instead of, the fines and penalties provided for in Section 7.01, any Person violating or disobeying any section or part of this Ordinance, or any other federal, state, local, or District law, rule, or regulation, may be required to make restitution for damage resulting from such violation(s). The provisions of the Illinois Parental Responsibility Law (740 ILCS 115/1 *et seq.*) are specifically incorporated in this Ordinance by reference for purposes of this section.

Section 7.03. Seizure/Removal/Impoundment of Property. Any property, substance, or thing brought into, utilized, placed, or left on District Property in violation of this Ordinance, or any other District ordinance, rule, or regulation may be removed, seized, and destroyed in the case of property and substances referred to in sections 2.02, 2.03, 2.10 and 2.41, or seized and impounded in the case of any other property, substance or thing (including without limitation Vehicles and bicycles). Property so impounded shall not be returned to the owner(s) thereof until such Person(s) provides the District with acceptable proof or evidence of ownership and until such Person(s) has reimbursed the District in full for all costs and expenses to the District of such impoundment including without limitation any removal and storage charges. Property not claimed by the rightful owner(s) thereof within sixty (60) days after such impoundment may be sold by the District which shall be entitled to the entire proceeds thereof, or otherwise disposed of. Any motor Vehicles towed and/or impounded shall be disposed of according to the applicable laws of the State of Illinois.

Section 7.04. Non-Exclusivity of Penalties. The penalties provided for in this Chapter 7 are in addition to and not exclusive of any other remedies available to the District as provided by applicable law. The penalties provided for in section 7.01 may be imposed or assessed in addition to and not necessarily in lieu of the penalties provided for in section 7.02, and vice versa.

CHAPTER VIII - REPEAL

All District ordinances, resolutions, policies, rules and regulations in conflict or inconsistent with any of the provisions of this Ordinance are hereby repealed.

CHAPTER IX - SEVERABILITY

Provisions of this Ordinance shall be deemed to be severable. Should any section or part of this Ordinance be declared invalid by a court of competent jurisdiction, the remaining part or parts of such section and/or the other sections, as the case may be, of this Ordinance shall nevertheless be valid, binding and subsisting.

CHAPTER X - PUBLICATION AND EFFECTIVE DATE

Section 10.01. Publication in Book Form. In lieu of other publications, this Ordinance shall be published in book or pamphlet form, and when so published, shall become effective with the same force and effect as if otherwise published. Such book or pamphlet shall be received as conclusive evidence of the passage and legal publication of this Ordinance in all courts and other places without further proof of the passage and publication of this Ordinance.

Section 10.02. Effective Date. This Ordinance shall take effect and be in force ten (10) days after the date of its passage, approval, and publication in book or pamphlet form as provided for herein.

PASSED by the Wheeling Park District Board of Commissioners by roll call vote this 7th day of January 2014.

ROLL CALL VOTE:

AYE: C. KLUMPP, M. BURNS, S. STEIN, M. KURGAN, B. LICHTENBERGER, R. ROSEN, K. PECKA

NAY: NONE

ABSENT: NONE

APPROVED this 7th day of January 2014.



President, Board of Park Commissioners

ATTESTED and RECORDED this
7th day of January 2014, and published in pamphlet
form this 7th day of January 2014.



Secretary, Board of Park Commissioners